

SERVICE INFORMATION LETTER

Subject: Installation Recommendations for Wencor Tubular Rivet PN 800162WE, installed in the JT8D Engine 7th Stage High Pressure Compressor (HPC) Disk.

1. Planning
 - a. Effectivity

Wencor P/N	NHA P/N	NHA Description	ATA	Engine Application
800162WE	815707 5006007-02 and similar	Disk- Compressor Rotor, 7 th Stage	72-36-00	JT8D-ALL

2. Reason

During an investigation of in-service failed Wencor Tubular Rivets PN 800162WE as described in Service Bulletin 130617-001, Wencor discovered contributing factors in the rivet failure that occurred during the process of installing and flaring the rivet during the assembly of the 7th stage disk. This SIL provides some recommended installation and flaring actions (see section 4) to the assembly process that will reduce the potential of in-service rivet failure.

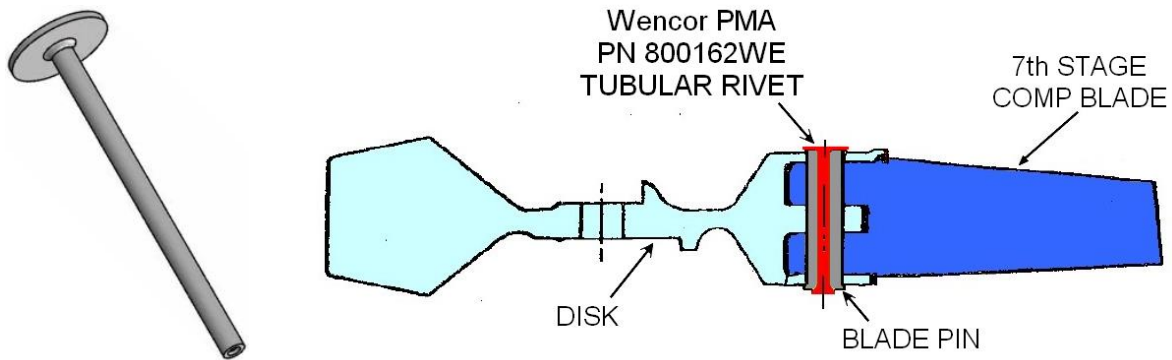

Figure 1, Rivet ISO View & Section View of Installed Rivet

3. Background

The investigation showed the failure mode of the rivet to be fracture and liberation of the rivet head. In all cases, the fracture was located at the radius between the rivet head and shank as shown in Figure 2.

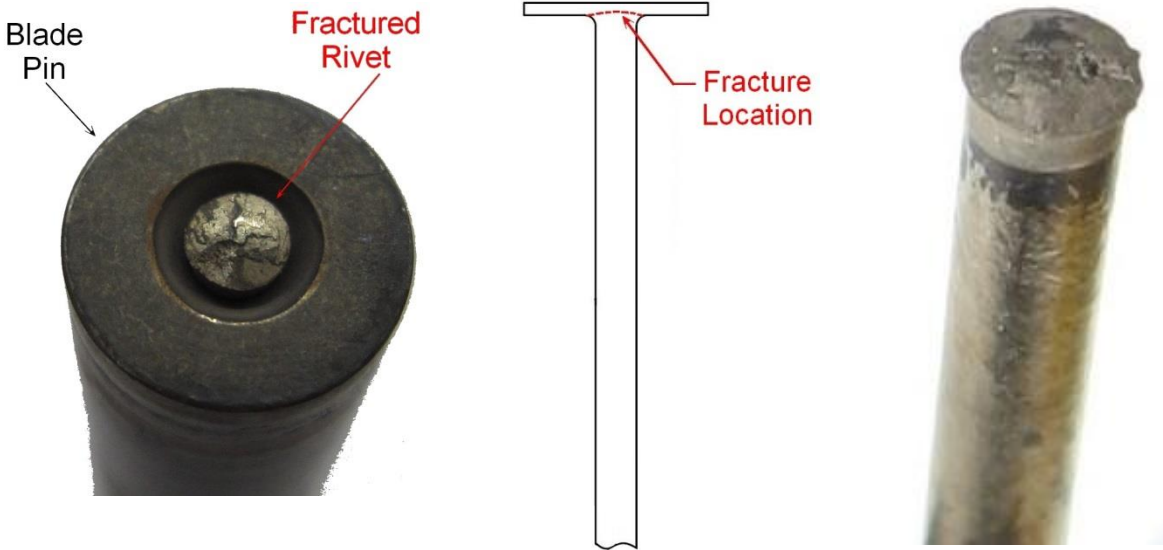

Figure 2, 3 Images of Rivet Fracture

The potential fracture of the rivet can be reduced by minimizing the stress at the radius between the rivet head and shank. The investigation of the failed rivets showed two areas in the rivet installation and flaring process that could introduce undesirable stresses at the rivet radius.

a) Gaps Under Rivet Head

As shown below in Figure 3, examination of some rivets still installed in the disk showed that the rivet heads were not setting flat or parallel against the blade pin or disk surface after installation. This results in a gap between the underside of the rivet head and top side of the blade pin. Wencor considers any gap that is larger than .003" a contributing factor that could cause stress in the rivet radius that could contribute to head liberation.

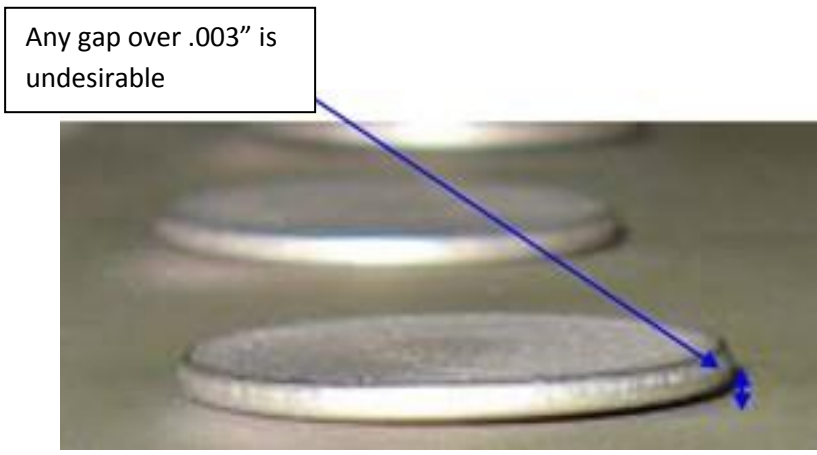

Figure 3, Showing Undesirable Gap Under Rivet Head

The gap shown in Figure 3, results in uneven contact between the underside of the rivet head and the blade pin. The uneven contact is shown by witness marks on the underside of the rivet head as shown below in Figure 4. The uneven contact creates an undesirable bending stress at the rivet radius which could contribute to head liberation.

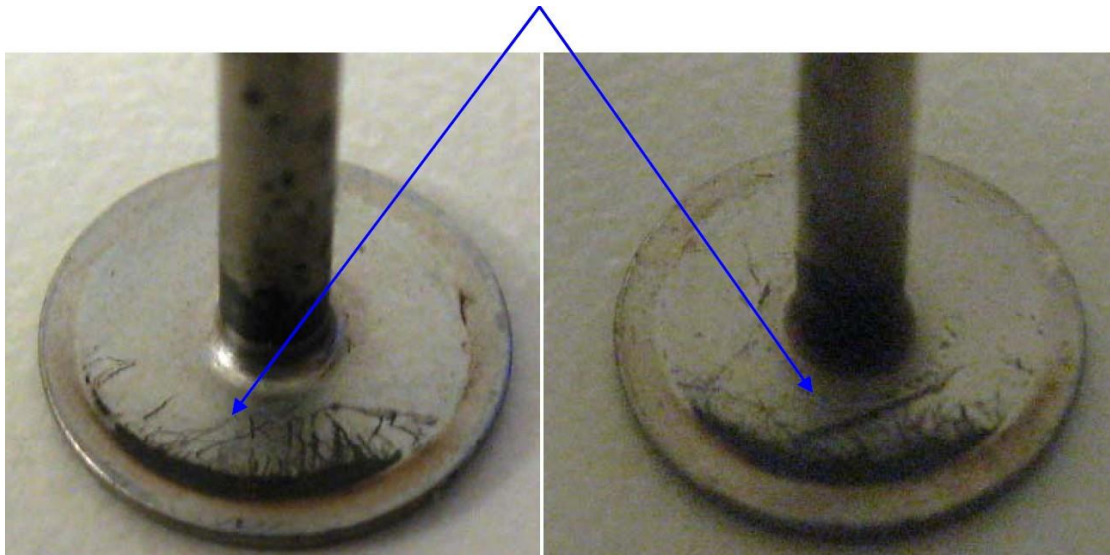

Figure 4, Witness Marks Due to Uneven Contact on Rivet

b) Incomplete Support During Rivet Flaring

During the rivet flaring process, the rivet head is supported by a tool that incorporates a mandrel that should support the entire rivet head while the rivet is flared (see Figure 6 & 7). As shown below in Figure 5, examination of some of the rivets still installed in the disk showed evidence of incomplete support of the rivet head during the flaring process. If the entire rivet head is not supported during the flaring process, a bending stress would be generated at the rivet radius which could contribute to head liberation.

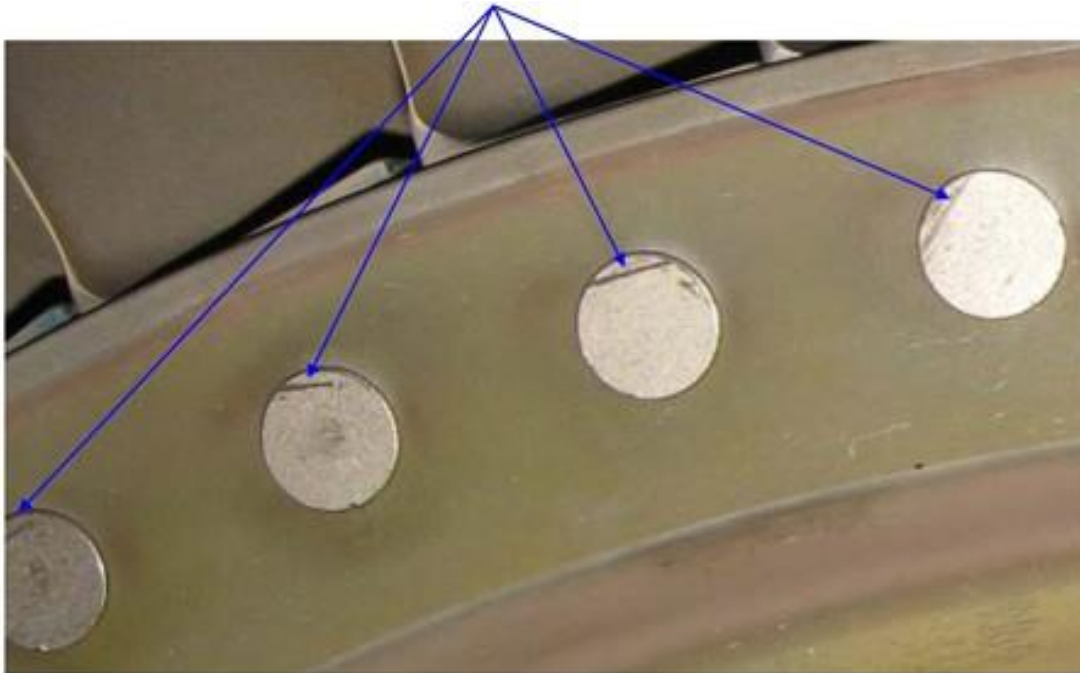

Figure 5, Witness Marks Showing Incomplete Rivet Head Support

4. Recommended Actions

a. Verify Complete Rivet Head Support During Rivet Flaring

During the rivet flaring process, when the rivet is installed into the 7th stage disk and the disk is set upon the disk support tool (PWA 33565) as shown below in Figure 6 and described in step 1 of task 72-36-02-44-003-002 (JT8D-1/17 EMM for PN 481672) or in task 72-36-02-44-003-003 (JT8D-209/219 for PN 773128). Prior to flaring the rivet, the rivet head must be fully supported by the mandrel as shown in Figures 7 & 7a.

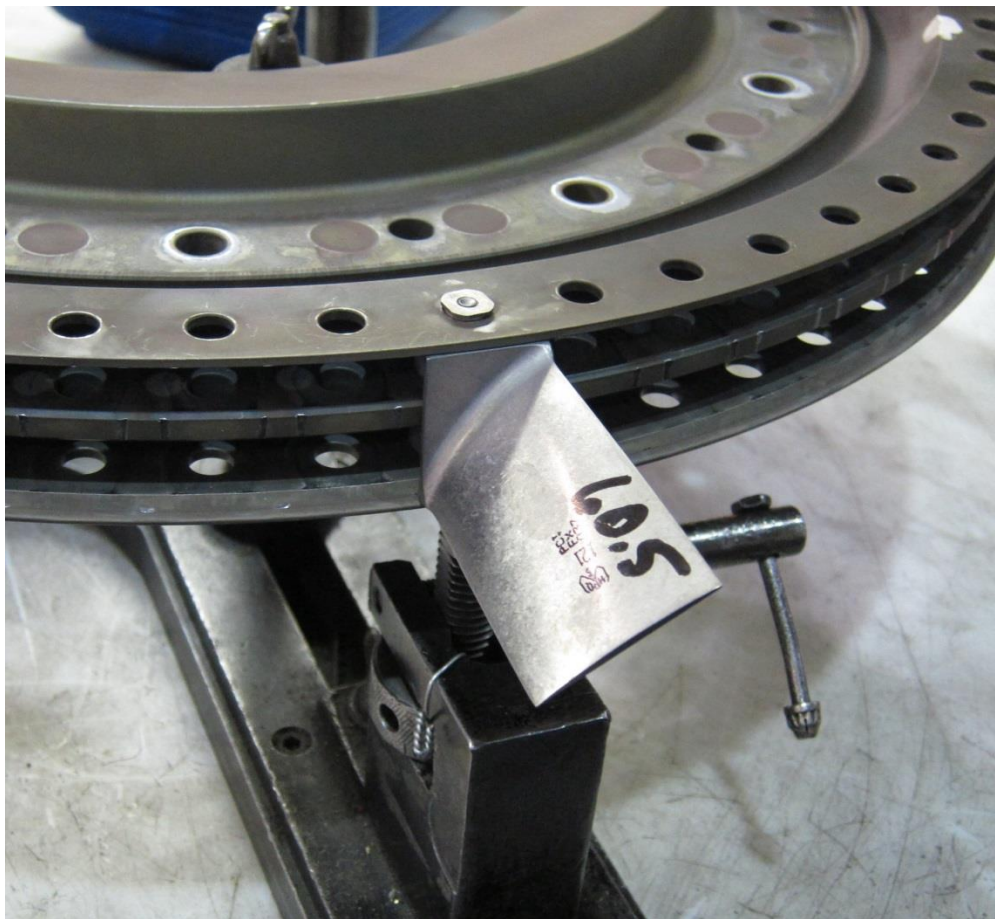
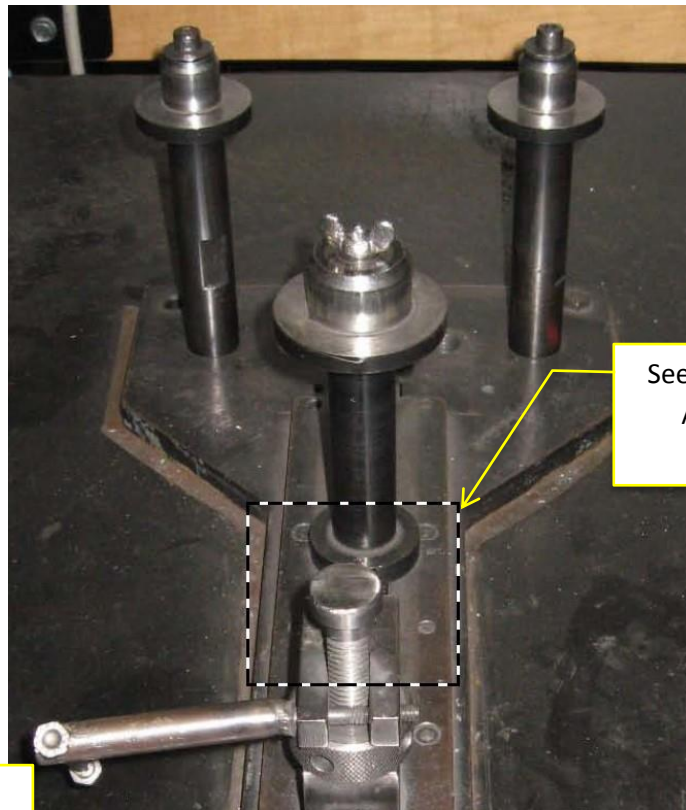

Figure 6, 7th Stage Disk Assy Set Upon Support Tool



Simulated Rivet Head
Correct Position, Fully
Supported By Mandrel

Simulated Rivet Head
Incorrect Position, Only Partly
Supported by Mandrel

Figure 7, Disk Support Tool

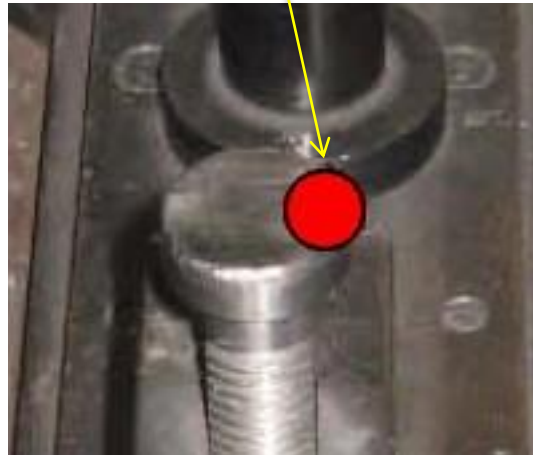
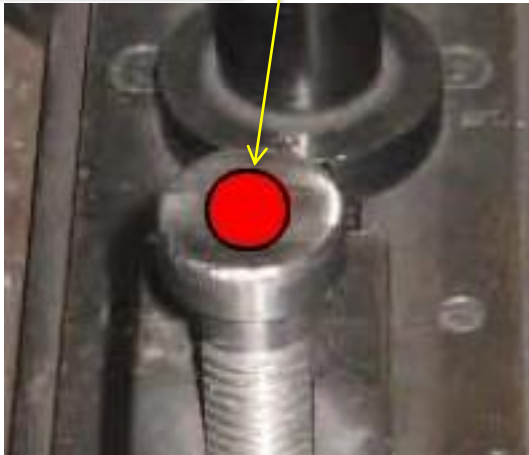

Figure 7a, Showing Simulated Rivet Head Position

b. Verify Minimal Gap Under Rivet Head at Installation

After the rivet flaring process, during step 2 of task 72-36-02-44-003-002 (JT8D-1/17 EMM for PN 481672) or in task 72-36-02-44-003-003 (JT8D-209/219 for PN 773128), verify that the gap between the rivet head and the blade pin as shown in Figure 8 does not exceed .003”.

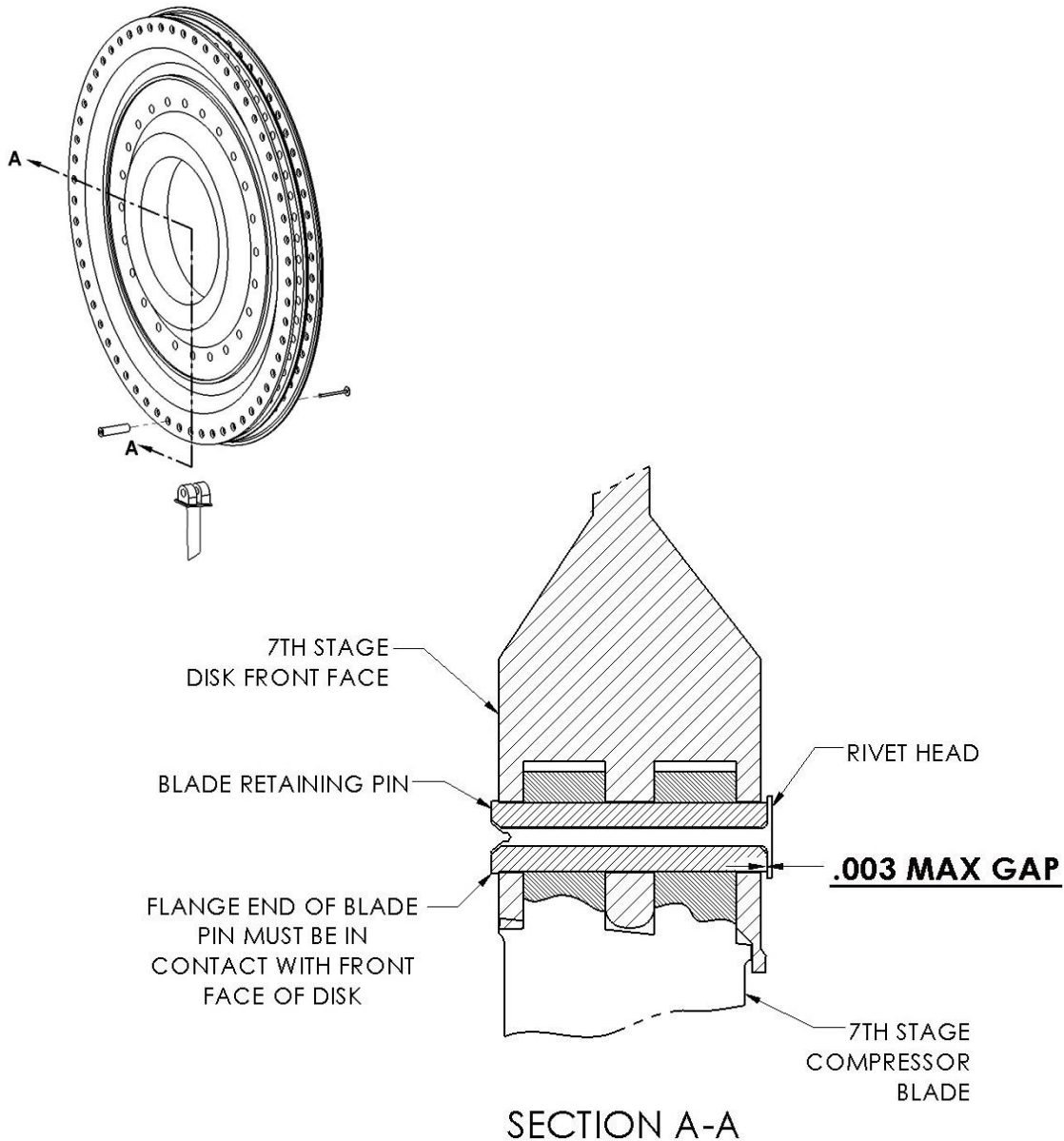

Figure 8, Installed Rivet with .003” Max Gap Under Head



A WENCOR GROUP Company

1625 North 1100 West
Springville, UT 84663
801-489-2000

5. Comments/Questions

For general comments and/or questions regarding this SIL, please contact the applicable Wencor sales representative by calling 801-489-2000 or email: sales@wencor.com. For technical questions regarding this SIL please contact Jon Bies at jbies@wencor.com.